



GASOLINE SHREDDER

Original Operation Manual

RAMBO-HC15



ATTENTION! The machine is delivered without engine oil and fuel.

Both the model number and serial number can be found on the nameplate on the machine. You should keep both numbers safe so that you can refer to them in the future. This manual explains the functions and applications of the machine.

FOR YOUR SAFETY

**Read the user manual before commissioning.
Safety and warning instructions must be observed!**

Overview

1. Preface

- 1.1 Information on the user manual
- 1.2 Limitation of liability
- 1.3 Machine designation
- 1.4 Copyright protection
- 1.5 Reservations

2. Intended use

3. Operating hours restriction

4. Environment

5. Safety

- 5.1 Warning instructions
- 5.2 Safety instructions
- 5.3 Personal protective equipment (PPE)
- 5.4 Transport
- 5.5 Safe handling of operating materials / refuelling
- 5.6 Service security
- 5.7 Electrical system
- 5.8 Residual dangers and protective measures
- 5.9 Behaviour in an emergency

6. Used warning and information symbols

7. Machine overview

- 7.1 Shredder
- 7.2 Gasoline engine

8. Functions

- 8.1 Engine
- 8.2 Device unit

9. Technical data

- 9.1 Electrical connection
 - 9.1.1 Electric start
 - 9.1.2 Safety circuit (EMERGENCY STOP)

10. Technical description

11. Standard equipment

12. Assembly

13. Drive type

- 13.1 Gasoline engine
- 13.2 Refuelling
 - 13.2.1 Filling up engine oil
 - 13.2.2 Fuelling

14. Commissioning

- 14.1 Preparation for the site of operation
- 14.2 Start process
- 14.3 Switching off the engine
- 14.4 Stopping the engine in an emergency
- 14.5 Idle speed

15. Shredding operation

- 15.1 What may be shredded
- 15.2 Shredding

16. Maintenance and repair work

- 16.1 Maintenance work
- 16.2 Maintenance plan
- 16.3 Lubricants
 - 16.3.1 Greasing the blade chassis
 - 16.3.2 Changing the engine oil
- 16.4 Blades
- 16.5 Drive belt
 - 16.5.1 Check drive belt for wear and tension
 - 16.5.2 Changing the drive belt
- 16.6 Changing / cleaning the air filter
- 16.7 Checking / replacing / cleaning the spark plug
- 16.8 Safety installations
- 16.9 Checking wheels and tyre pressure
- 16.10 Rubber protection flap
- 16.11 Cleaning the machine
- 16.12 Checking, retightening the fastening elements
- 16.13 Checking, repairing the construction

17. Transport

- 17.1 Transport by hand
- 17.2 Transport with chassis

18. Storage

19. Disposal

- 19.1 Decommissioning
- 19.2 Disposal of electrical equipment
- 19.3 Disposal of lubricants

20. Troubleshooting

21. Warranty / Guarantee / Customer Service

22. EC Declaration of Conformity

23. Components RAMBO-HC15

1. Preface

Read the entire text of the operation manual before assembly and commissioning. Use these instructions to familiarise yourself with the machine, its correct use as well as the safety instructions.

1.1 Information on the user manual

This user manual provides important instructions on the use of the RAMBO-HC15 gasoline shredder. A prerequisite for safe working is the correct observance of all specified safety instructions and handling instructions. In addition, the local accident prevention regulations and general safety regulations applicable to the area of use of the machine, must be observed.

1.2 Limitation of liability

We have made every effort to inform you as comprehensively as possible about accident prevention when operating the machine, but accept no liability for incomplete information about listed danger points and sources.

The manufacturer accepts no liability for damage due to:

- Non-compliance with the user manual
- Improper use of the machine
- Improper assembly, commissioning, operation and maintenance of the machine
- Operating the machine with defective safety installations or improperly installed or non-functioning safety and protective devices
- Failure to observe the instructions in the user manual regarding transport, storage, function, operation, maintenance and care of the machine
- Unauthorised structural changes to the machine
- Inadequate monitoring of machine parts subject to wear and tear
- Improperly performed repairs
- Disaster situations caused by foreign bodies and act of God

1.3 Designation machine

The designation machine replaces the trade name of the object to which this user manual - see cover sheet - refers.

1.4 Copyright

All documents are protected by copyright. A passing on and duplication of documents, also in extracts, as well as communications of the contents to third parties are not permitted, as far as not expressly agreed.

1.5 Reservations

Information on technical data, dimensions and illustrations of the machine, as well as changes in safety standards, are subject to further development and are therefore not binding for the delivery in every case.

Errors in printing and wording reserved.



IMPORTANT NOTICE!

The machine is delivered without engine oil.

ENGINE OIL must be filled up before the first commissioning!

2. Intended use

The gasoline shredder - RAMBO-HC15 - is designed exclusively for shredding bushes, shrubs, barks and branches up to a thickness of 12 cm. The machine is not suitable for preparing garden soil.

Roots with soil, stones, glass, metal, textiles, kitchen waste, cardboard or plastic must never be shredded with the machine.



CAUTION!

Cutting waste from conifers or similar dense cuttings can lead to blockages!

The machine is designed for operation by 1 person only. Never allow two or more people to work on the same machine.

The safety, working and maintenance instructions from the manufacturer, as well as the dimensions specified in the technical data must be observed.

Any other use is contrary to the intended use. Unintended use, modifications to the machine or the use of parts that have not been tested and approved by the manufacturer can cause unforeseeable damage!



WARNING!

Possible misuse

- Safety installations must not be dismantled or bypassed.
- Use of non-approved accessories.
- The machine must not be operated for commercial purposes.

Persons who are not familiar with the user manual, children, young people as well as persons under the influence of alcohol, drugs or medication must not operate the machine.

3. Operating hours restriction

In residential and small residential estates or on the grounds of hospitals and nursing homes, shredders may not be operated all day on Sundays and public holidays as well as from 8.00 p.m. to 7.00 a.m. on workdays.

Please also observe the regional regulations on noise protection.

4. Environment

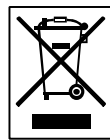

Please recycle waste material and do not dispose of it as waste. All tools, hoses and packaging must be sorted, taken to the local recycling depot and disposed of in an environmentally friendly manner.

The site of operation must be protected against contamination with leaking operating materials. Used or residual operating materials must be recycled in accordance with the environmental protection regulations in force at the site of operation.



Ask your local waste disposal authority about the possibilities of environmentally friendly and proper disposal.

5. Safety

This section provides a comprehensive overview of all important safety aspects, for adequate protection of the operator, as well as for safe and trouble-free operation.

Failure to comply with the guidelines and safety instructions in this manual may result in considerable hazards.

5.1 Warning instructions

Warning instructions are identified by symbols in this user manual. The safety instructions are introduced by signal words expressing the extent of the hazard.

The instructions must be observed at all times in order to avoid accidents, personal injury and damage to property.



DANGER!

Failure to follow this manual may result in death and / or life-threatening injury.



WARNING!

Failure to follow this manual may result in death and / or serious injury.



CAUTION!

Failure to follow these instructions may result in minor or moderate injury.



IMPORTANT NOTICE!

Failure to follow this manual may result in damage to the engine or other property.

5.2 Safety instructions



WARNING!

Familiarise yourself with the machine. Proper training is a prerequisite for safe operation of this machine. Incorrect operation or operation by untrained personnel may present a danger.

Read the operation manual for this machine carefully and observe the labels affixed to the machine. Familiarise yourself with the application and restrictions, as well as the specific, potential dangers associated with it.

Also familiarise yourself with the control panels and their proper use. Learn how to stop the machine and turn it off quickly. Inexperienced operators must be instructed by personnel familiar with the machine. Only then are they allowed to operate the machine.

In addition to the work safety instructions in this user manual, the safety, accident prevention and environmental protection regulations valid for the area of application of the machine, as well as the road traffic regulations, must be observed.

Responsibility of the user

The user must make the user manual available to the operator and ensure that the operator has read and understood it. The user manual must be handed over at the same time. In addition, he must train the personnel at regular intervals and inform them about the dangers involved in handling the machine.

Furthermore, the user is responsible for ensuring that the machine is always in technically perfect condition.

Responsibility of the operator

Only trained persons may start, operate and switch off the machine. The operator must be trained in the correct operation of the machine and be familiar with the necessary safety devices. Inadequately informed operators can endanger themselves and other persons through improper use.

First-time users should be instructed by the seller in order to familiarise themselves with the characteristics of the machine, its intended use and the necessary safety devices.

Operating personnel



WARNING!

Persons who are not familiar with the user manual, children, young people under the age of 18 as well as persons under the influence of alcohol, drugs or medication must not operate the machine. Young people from the age of 16 may use the machine under the supervision of a trained person.



The machine is only designed for the operation by 1 person! Never allow two or more persons to operate and load the machine.

The presence of children or other persons in the working area during shredding is prohibited. Watch out for animals too.

The machine may only be operated outdoors and not in closed rooms.

The operator is liable for all damages to third parties and their property.

Workspace

Working with the machine requires a high level of attention.

- **Pay attention to the environmental conditions at the workplace.** A level and tread-proof area with sufficient freedom of movement is required for working. Please also pay attention to the safety against overturning!
- **Ensure sufficient lighting conditions in the working and surrounding area of the machine.** Poor lighting can significantly increase the risk of injury!
- In bad weather and on uneven terrain, make sure that you have a secure footing. **Slip hazard!**

Operation



WARNING!

The shredded material is ejected from the machine at high speed. Always wear safety goggles!

Never put a damaged machine into operation!

Only work when in good physical condition.

Carry out all work calmly and prudently.

Never leave the machine running unattended.

When starting the engine, do not stand in the area of the ejection openings.

Do not start shredding until the gasoline engine has reached maximum speed.

Never force the material into the machine. Hold longer branches tightly when filling. Wear suitable protective equipment (e.g. safety goggles, ear protection, gloves and sturdy shoes).

Always operate the machine from the side of the infeed chute. It is forbidden to stand in front of the ejection chute when the machine is in operation.

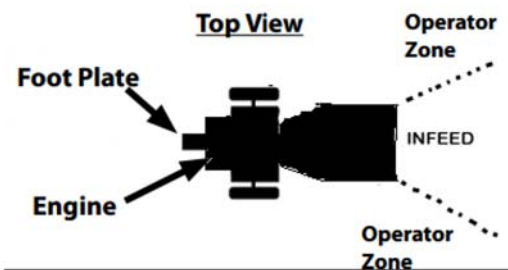

Working position

Keep face and body away from the infeed chute.

Never reach into the infeed or ejection chute.

Only work with sharp blades, this reduces the risk of kickback

To avoid injury, keep fingers, hands, and feet away from the infeed chute and the ejection chute.

If handled improperly, the sharp edges of the blades can pose a significant risk of injury. Make sure that the two shredding blades and the counter blade are correctly installed and securely fastened. Failure to do so may result in serious injury.

Never operate the machine without protective and safety devices. Unattached protective and safety devices are a source of danger and can cause serious injury.

If the machine comes into contact with a foreign object, switch off the engine and remove the spark plug. Check the machine for possible damage. Have the damage repaired before restarting the machine and continuing to work.

If there are any blockages on the cutting unit and ejector, switch off the engine, remove the spark plug and clean the cutting unit with a suitable tool.

Always turn off the engine when there is a delay in shredding or when moving the machine from one location to another.

Caution with rotating tools - **keep a safe distance!**

Be careful with spinning blades. Shredding blades can spin due to the flywheel mass. Only when the blades have come to a complete standstill, the motor switch is in the OFF position and the spark plug connector has been removed, may work be carried out on the machine.

Do not reach into the running machine (infeed chute / ejection chute) during the function test of the shredding blades.

Never work without protective devices. The effectiveness of the safety and protective devices must not be inadmissibly influenced or cancelled.

Commissioning of the machine at a higher speed than recommended in the *technical data* may damage the motor. **High speed increases the risk of accidents!**

The drive must be switched off immediately in the event of noticeable changes in the behaviour of the machine.

End of work

Do not leave the machine running unattended while the engine is running.

When leaving the machine (even for short interruptions), switch off the engine and secure the machine against unauthorised use. For model versions with an ignition key, pull it out, otherwise remove the spark plug connector.

Park the machine so that it cannot tip over, fall down or slide away.

Store the machine properly when not in use. After operation, store the machine in a locked, clean, frost-protected and dry place that is inaccessible to children.

5.3 Personal protective equipment (PPE)

When handling the machine, it is essential to wear personal protective equipment (PPE) to minimise

any risk to the operator. The following protective measures must be observed:

- Tight-fitting **work clothes** that do not hinder movement. It is mainly used to protect against being caught by moving parts.
- **Noise protection devices** such as hearing protectors, capsules, etc. to protect against hearing damage.
ATTENTION! Noise can be harmful to health. If the permissible noise level of 80 dB(A) is exceeded, hearing protection must be worn.
- **Mouthguard** to protect against respiratory diseases, to retain fine dust or particles.
- **Safety goggles with side protection** to protect eyes from dust or splinters.
- **Work gloves** made of strong leather, to protect against sharp edges, splinters or excessive vibration.
- **Safety shoes or boots** with steel caps to protect against uneven, sharp-edged surfaces or falling objects. The safety footwear also ensures a safe stand.
- **Safety helmet** to protect the head from falling parts and swinging loads. It can also prevent injury in confined situations.

5.4 Transport

For transport on motor vehicles or trailers and before each change of location, switch off the engine and wait for the working tools to come to a standstill. Then disconnect spark plug connector and close fuel switch (if present).

Only transport the machine upright.

5.5 Safe handling of operating materials / refuelling



WARNING!

Combustion engines pose a particular danger during operation and refuelling. Always read and follow the warning instructions and, in parallel, the additional safety instructions given later in this manual. Failure to do so may result in serious or even fatal injury.

Do not start or run engine indoors, in garages, or in enclosed areas. The exhaust gases from the engine contain toxic carbon monoxide. Being in an

environment containing carbon monoxide can cause unconsciousness and death.

Before refuelling, switch off the engine and allow it to cool down.

Smoking and any open fire are not allowed.

Fuels may contain substances similar to solvents. Avoid skin and eye contact with mineral oil products. Wear gloves when refuelling.

Do not spill fuel or oil. If fuel or oil is spilled, clean the machine immediately. Do not allow fuel to come into contact with clothing. If fuel gets on clothing, change clothing immediately.

Make sure that no fuel or oil gets into the soil (environmental protection!). Use a suitable base.

Carefully loosen the fuel tank cap to allow the existing pressure in the tank to slowly release. Check fuel lines, fuel tank cap, and tank for leaks or cracks. The machine must not be put into operation with such damage.

Close the fuel tank cap tightly after refuelling.

To start the machine, change location (at least 3 meters away from the fuelling area).

Fuels cannot be stored indefinitely. Only buy as much as will be consumed in a few months. Do not use old fuel!

Transport and store fuel and oil only in approved and marked canisters.

Do not transport or store fuel and oil near combustible or highly flammable materials as well as sparks or open flames.

Never use a machine with a damaged ignition cable and spark plug connector. Danger of sparking!

Fuels and oils must be kept out of reach of children in accordance with safety regulations.

5.6 Service security



WARNING!

Repair, set-up, maintenance and cleaning work, as well as transporting the machine, may only be carried out when the drive is switched off and the

blade is at a standstill. In the event of a malfunction, operation must always be switched off. Moving parts can cause serious injuries.

On machines with gasoline engines, disconnect the spark plug connector and unscrew the spark plug before carrying out repair, set-up, maintenance and cleaning work in order to prevent unintentional starting.

Always ensure that the machine is in safe operating condition, in particular check the fuel system for leaks.

If protective devices and work blades are subject to wear, they must be checked regularly and replaced if necessary.

Damaged cutting blades (cracked, chipped or otherwise damaged) must be replaced immediately. When replacing the shredding blades, use suitable blades and wear protective gloves.

Regularly check the screw connections for tight fit and retighten if necessary.

Always keep the controls of the machine dry and free of resin, oil, and grease.

After repair, set-up, maintenance and cleaning work, always fit the protective and safety devices on the machine and put them in the protective position.

Work on the electrical system may only be carried out by qualified electricians.

Use only original – LUMAG – spare parts and accessories. The use of other spare parts and accessories may increase the risk of accidents. Any liability for damages resulting from this is excluded.

5.7 Electric shelf

Wearers of a pacemaker must not touch the live parts of the ignition system when the engine is running.

5.8 Residual dangers and protective measures



WARNING!

Disabling, modifying, blocking, dismantling, modifying or attaching any parts to the safety and protective devices of the machine is strictly prohibited and may result in serious and / or fatal injuries if not observed.

Mechanical residual dangers

Capturing, coiling

The machine can grasp and pull in pieces of clothing, cords, wires and other foreign bodies.

→ Check the shredded material for foreign bodies. Wear tight-fitting clothes.

Pulling in, catching

Rotating parts such as the cutting unit can pull in and catch wide clothes.

→ When handling the machine, it is essential to wear personal protective equipment (PPE).

Crushing

Careless guidance of the shredded material can lead to serious injuries.

→ Slowly and carefully feed the shredded material into the infeed chute.

→ Do not reach into the chute. **Automatic infeed!**

→ Always insert branches with the thick end first.

→ Keep a sufficient safety distance.

→ Operate the machine calmly and carefully.

→ Pay attention to bystanders!

Neglecting ergonomic principles

Negligent use of personal protective equipment (PPE)

Careless use or omission of personal protective equipment can result in serious injury.

→ Wear the prescribed protective equipment.

Insufficient local lighting

Poor lighting poses a high safety risk.

→ Always ensure sufficient lighting at the workplace.

Human behaviour, misbehaviour

→ Always concentrate during work.

Residual danger can never be excluded.

Electrical residual dangers

Direct or indirect electrical contact

Touching live parts when electrical or defective components are open or electrical connection cables which are not properly connected can lead to injuries.

→ Never touch the spark plug connector or the spark plug when the engine is running.

→ Have defective cables or plugs replaced by a specialist.

→ Disconnect the mains plug before maintenance work.

→ Only use the machine on a connection with a residual current circuit breaker (RCCB).

Thermal residual dangers

Burns, chilblains

Touching hot surfaces can cause burns.

→ Allow the engine to cool down. Always ensure that the motor is adequately ventilated.

Noise hazard

Hearing damage

Prolonged, unprotected work with the machine can lead to hearing damage.

→ Always wear hearing protection.

Hazard due to materials and other substances

Contact, inhalation

Ejected objects or liquids can cause damage to health.

→ When shredding, mechanical particles can injure their eyes. Always wear safety goggles!

→ Exhaust gases can cause damage to health. Use power tools outdoors only and take regular breaks.

→ Hydraulic oils are toxic. Supply fresh air after inhalation of mist or vapours. After eye contact, rinse thoroughly (at least 10 minutes) with water, then consult an ophthalmologist.

Fire, explosion

Fire and slip hazard due to spilled fuel or hydraulic fluid.

→ Smoking, fire and open light are prohibited during operation!

→ Clean up spilled liquid immediately with oil binding agent and dispose of according to regulations.

Other hazards

Slipping, tripping or falling of persons

On unstable and uneven surfaces, tripping can cause you harm.

→ Watch out for obstacles in the working area. Always make sure you have a secure footing and wear safety shoes.

5.9 Behaviour in an emergency

In the event of an accident, initiate the appropriate first aid measures and request qualified medical assistance as soon as possible.

When requesting assistance, provide the following information:

Where it happened - what happened - how many injured persons - what type of injury - who reports!

6. Warning and information symbols used

There are symbols on the machine that represent important information about the product and instructions for use.



ATTENTION!

This is about your safety. The symbol indicates a danger, warning or caution.



Read and observe the user manual and safety instructions before commissioning.



Before cleaning, maintenance and repair work, switch off the engine and disconnect the spark plug connector.



DANGER!

Health and explosion hazard due to combustion engine



The exhaust gas of the engine contains toxic carbon monoxide. Being in an environment containing carbon monoxide can cause unconsciousness and death.



Do not run the engine in a closed room.



Keep the machine away from heat, sparks as well as flames. Do not smoke near the machine.



Gasoline is extremely flammable and explosive. Before refuelling, switch off the engine and allow it to cool down.



Use unleaded fuel ROZ95 or higher.

MANDATORY SIGNS



Read these instructions completely before using the machine. Failure to do so increases the risk of injury to the operator and other persons.



Wear safety shoes with steel caps.



Wear protective gloves.



Wear eye protection.



Wear hearing protection.



Check engine oil!

Check the oil level before each use and after at least 8 hours of operation (OH).



Never remove or tamper with protective or safety devices.



Warning of hot surfaces.

Risk of burns!

Do not touch hot engine parts. These remain hot for a short time even after the machine has been switched off.



Getting caught in the spinning belt will cause a hand injury.

Always fit the belt guard.



WARNING! Keep hands and feet away from rotating blades.

Do not reach into openings, the infeed chute or the ejection chute when the engine is running.



WARNING! Keep hands away from rotating parts.

Only touch machine parts when they have come to a complete standstill. Never open or remove protective devices while the engine is running.



WARNING! Danger from ejected objects when the engine is running.

There is a risk of branches, garden waste or other materials being suddenly ejected. For this reason, uninvolved persons as well as pets and farm animals must never be in front of or next to the shredder.

Keep a sufficient safety distance of at least 12 metres when the engine is running.



Keep bystanders away from the work area.



Shredding of branches of all kinds
up to max. 120 mm diameter, depending on the type of wood and freshness.



Electric start, ignition key
(12 V)

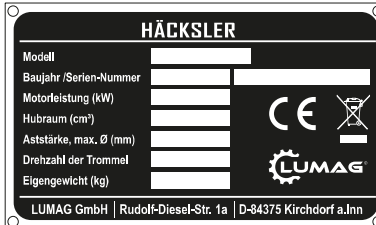

Nameplate

Equipped with model designation, year of manufacture and serial number. For spare parts orders and / or service information, please always provide this data.



Used electrical / motor appliances are recyclable materials and therefore do not belong in the household waste! Please dispose of the components in an environmentally friendly manner.

HINWEIS für Häcksler:

Bei Verstopfung die Maschine sofort ausschalten und den Stillstand der Schneidwerkzeuge abwarten!

Aufgrund des Überhitzens der Fliehkraftkupplung besteht Gefahr, dass Keilriemen und Kupplung Schaden nehmen.

NOTE for Wood Chipper:

In case of blockage, switch off the machine immediately and wait for the spinning blades to stop!

Due to the overheating of the centrifugal coupling, Risk of damage to belt and clutch.

7. Machine overview

7.1 Shredder

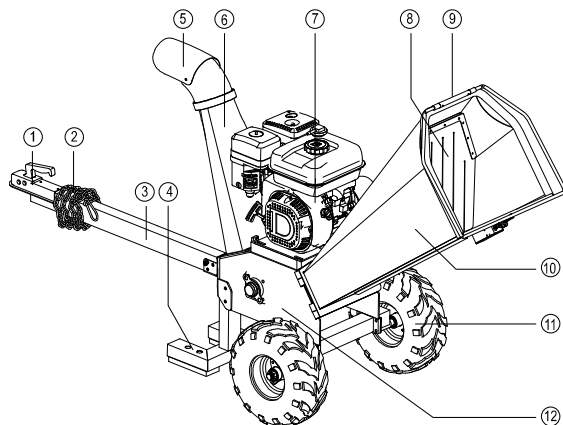

- 1 Trailer coupling
- 2 Safety chain
- 3 Drawbar
- 4 Foot
- 5 Adjustable deflector
- 6 Ejection chute
- 7 Gasoline engine
- 8 Rubber protection flap
- 9 Safety bar (EMERGENCY STOP)
- 10 Infeed chute, foldable
- 11 Transport wheel (2x)
- 12 Blade chassis

7.2 Gasoline engine

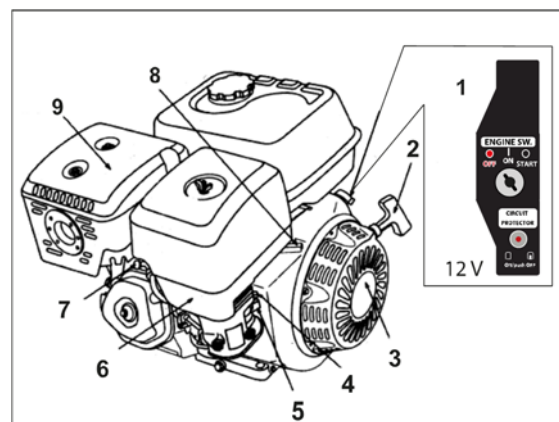

- 1 Engine switch (main switch)
= Ignition switch on E-start
- 2 Starter grip
- 3 Recoil starter
- 4 Choke valve
- 5 Fuel switch
- 6 Air filter
- 7 Spark plug, spark plug connector
- 8 Throttle lever
- 9 Muffler

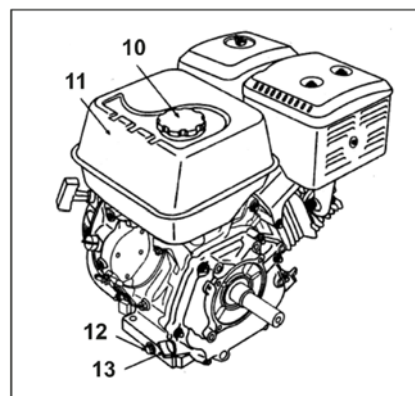

- 10 Fuel tank cap
- 11 Fuel tank
- 12 Oil drain bolt
- 13 Oil filler bolt with dipstick

8. Functions

8.1 Engine

Engine switch (main switch) = Ignition switch on E-start (1)

The engine switch in the OFF position prevents the machine (engine) from starting. To restart the engine, move the engine switch to the ON position, then start the engine as described in COMMISSIONING / start process (14.2).

Recoil starter, rope starter (2+3)

The starter is designed as a magneto ignition with spring reset. Incorrect handling of the recoil starter can damage the starter. Never wrap the recoil from the recoil starter around your hand.

Choke valve (4)

The choke valve opens and closes the choke flap of the carburettor. The choke valve is only used to start a cold engine.

Fuel switch (5)

The fuel switch opens and closes the connection between the tank and the carburettor.

Air filter (6)

The air filter consists of a foam pre-filter and a paper filter insert. It is located under the cover (6). A dirty air filter is noticeable by unclean running of the engine and black smoke.

Muffler (9)

The engine exhaust gets warm when the engine is running. Avoid touching the muffler when it is hot. Caution: Danger of burns!

Throttle lever (8)

The throttle can be reduced with the lever on the engine so that the engine idles and the blade drum stops.

Spark plug, spark plug connector (7)

Ignition takes place via an ignition cable and a spark plug connector, which is connected to the spark plug. Before starting the engine, check the spark plug connector for proper seating. Always disconnect the spark plug connector from the spark plug during adjustment and maintenance work.

Oil filler bolt with dipstick (13)

The engine oil is filled into the receptacle for the oil dipstick. DO NOT screw the dipstick down to check the oil level.

Oil drain bolt (12)

The oil drain bolt is located at the rear of the engine.

Fuel tank (11)

There is a fuel switch under the tank.

Centrifugal clutch

The engine has a centrifugal clutch coupled to the crankshaft. When the engine speed increases, the drive of the blade drum is automatically engaged.

8.2 Device unit

Safety circuit

EMERGENCY STOP bar (9) on the infeed chute

The engine can be stopped in dangerous situations by pressing the EMERGENCY STOP bracket (9).

There is another switch with the same function.

- Engine switch (ignition switch) (1) on the engine.



WARNING!

The blade drum trails for a short time due to the flywheel mass!

In case of unexpected circumstances, never hesitate to operate the EMERGENCY STOP bar (9) on the infeed chute.

Adjustable deflector (5)

The throwing range and throwing direction of the shredded material can be changed by adjusting the flap on the ejection chute.

Foldable infeed chute (10)

The infeed chute can be folded to the side for cleaning the blade drum, removing blockages and changing the blades.



DANGER!

Before commissioning of the machine, the infeed chute as well as the safety circuit must be refitted. Check the function of the safety circuit!

Drawbar (3)

A drawbar is provided for better guidance of the machine.



IMPORTANT NOTICE!

Dismantle the drawbar when loading!



CAUTION!

Never lift the machine by the infeed chute and / or ejection chute!

9. Technical data

Model number	RAMBO-HC15
Drive	4-stroke OHV Gasoline engine
Displacement	420 cm ³
Engine power, max.	9.0 kW*
Motor speed max.	3,600 1/min
Start system	Manual start, electric start
Speed of the blades	2,000 1/min
Fuel	Unleaded regular gasoline
Fuel volume	6.5 litres
Engine oil	SAE 10W-30 or SAE 10W-40
Oil tank volume	~ 1.1 litre
Spark plug	Type F7RTC or equivalent spark plug
Infeed chute	Branches up to Ø 120 mm
Guaranteed sound power level LwA	110 dB(A)
Weight	approx. 185 kg

* Actual performance in continuous operation is likely to be lower due to operating limitations and environmental influences.

° Max. wood diameter to be processed, depending on the type of wood and freshness.

The technical data applied at the time of printing and are subject to change without notice.

9.1. Electrical connection



WARNING!

Work on the electrical installation and electrical equipment may only be carried out by qualified electricians.

9.1.1 Electric start

The battery is already mounted on the chassis.



WARNING!

Before connecting, the key on the E-starter must be turned to the OFF position and removed.

Connect battery:

1. Turn ignition key on E-start (1) to OFF position and remove.
2. First connect the red wire to the positive terminal (+).
3. Then connect the green cable to the negative terminal (-).

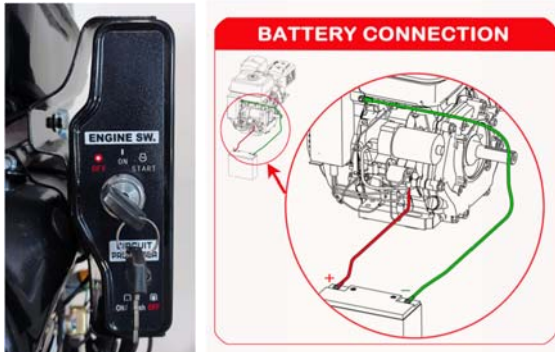

E-start

Connecting battery

9.1.2 Safety circuit (EMERGENCY STOP)

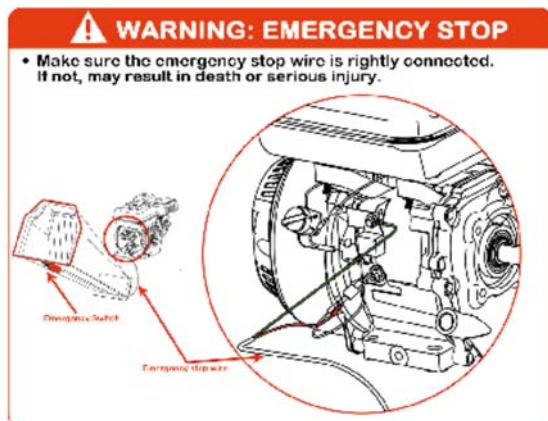

Connecting the safety circuit (EMERGENCY STOP)

10. Technical description

The shredder is used for shredding woody material, preferably in the garden area.

The machine is powered by a powerful 4-stroke OHV gasoline engine.

The blade drum - with two shredding blades and a counter blade - is driven by two V-belts.

The chopped material is ejected through the ejection chute by means of centrifugal force. Due to the cutting angle of the shredding blades and the arrangement of the counter blades, the branches are automatically pulled in. No insertion device is necessary.

The high ejection chute with adjustable deflector enables a targeted flow of shredded material for loading wheelbarrows and organic waste bins.

A wide chassis and wheels with pneumatic tyres allow comfortable transport. A support foot ensure a secure stand.

11. Standard equipment

After unpacking, check the contents of the carton and / or transport box for

- completeness
- possible transport damages

Immediately notify the dealer or manufacturer of any complaints. Later complaints will not be accepted.

The machine is delivered partially disassembled. The assembly work concerning point 12 must be observed.

If you have any questions or problems with the machine, please contact us.

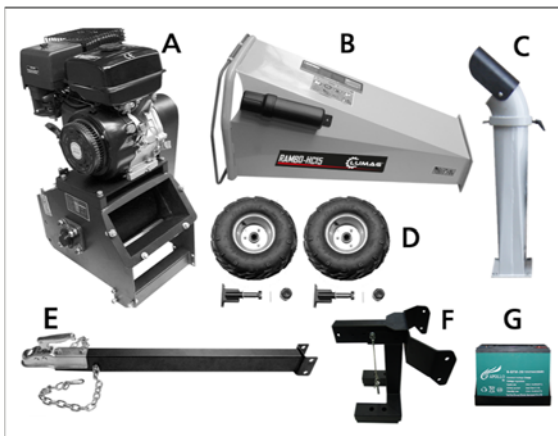

Standard equipment

- A Basic unit with gasoline engine and rotor
- B Infeed chute with safety circuit/bar (EMERGENCY STOP)
- C Ejection chute
- D 2 wheels, 2 axles, 2 splints, 2 wheel caps
- E Drawbar with trailer coupling
- F Foot
- G Battery

12. Assembly



IMPORTANT NOTICE!

At least two to three people are required for assembly. Fit the assembly parts with the engine switched off.

The machine consists of parts heavier than 20 kg. These parts must always be carried by at least two persons.

- Gasoline engine with rotor
- Infeed chute

If you have any questions or problems during installation, please contact us. You can reach us by email:

info@lumag-maschinen.de or by telephone at +49 8571/92 556-0.

To simplify the assembly process, we have divided the assembly instructions into several steps.

Step 1: Mounting the foot (F)

The foot is mounted on the rotor frame.

Screw the foot to the rotor frame with 4 screws, washers and nuts. To do this, the 2nd person tilts the motor slightly backwards.

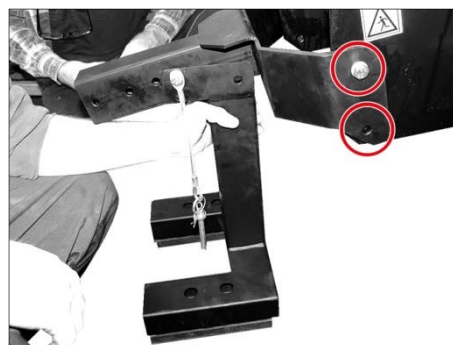

Mounting the foot

Step 2: Mounting the drawbar with trailer coupling (E)

The drawbar is mounted on the foot.

Mount the drawbar on the foot with 2 bolts M12x100, washers and nuts.



Mounting the drawbar with trailer coupling

Step 3: Mounting the wheels (D)

The wheels are mounted on the outside of the frame.

Insert the axle through the wheel rim. (Image 1/2/3)



Image 1



Image 2



Image 3

Tighten the castellated nut and secure it with the splint. (Image 4/5)



Image 4



Image 5

Then put on the hub cap. (Image 6)



Image 6

Repeat the process for the other wheel.



CAUTION!

A 2nd and 3rd person lift the machine. Pay attention to the weight!

The 2nd person lifts the engine by means of leverage, via the drawbar. A 3rd person helps from behind to lift the engine with frame and rotor.

Screw the axle to the rotor frame with 4 screws, washers and nuts. (Image 7/8)



Image 7



Image 8

ATTENTION! Check the screw connections again and retighten if necessary!

Step 4: Mounting the infeed chute (B)

Position the infeed chute so that the fastening rails of the infeed chute are aligned with the receptacles on the rotor frame. Afterwards, slide it on.

Now close the infeed chute and screw it to the rotor frame using 2 nuts on the screws already attached.

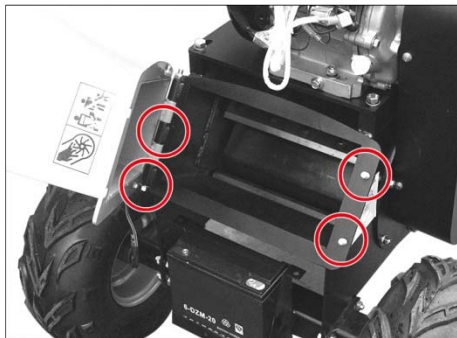

Mounting the infeed chute



WARNING!

Danger of cutting by cutting tools.

Step 5: Connecting the safety circuit (EMERGENCY STOP)

Plug the cable (a) into the cable lug of the cable (b).

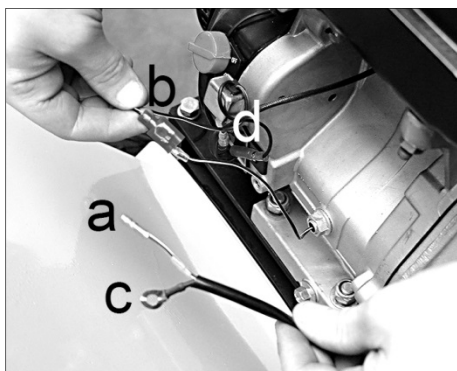

Then screw the cable (c) to the engine with the screws (d).

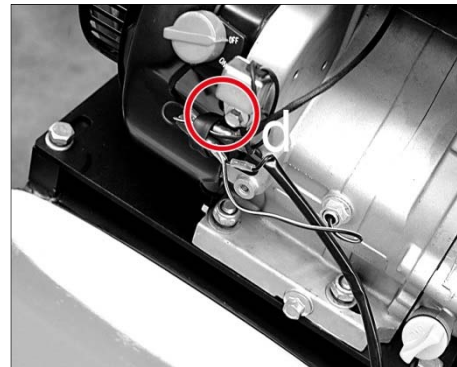

Connecting the safety circuit (EMERGENCY STOP)

Step 6: Mounting the ejection chute (C)

Position the ejection chute in such a way that the fixing holes on the rotor frame match the holes on the ejection chute.

With the help of a 2nd person, mount the ejection chute with 4 screws, washers and nuts.

Afterwards retighten all 4 screws!

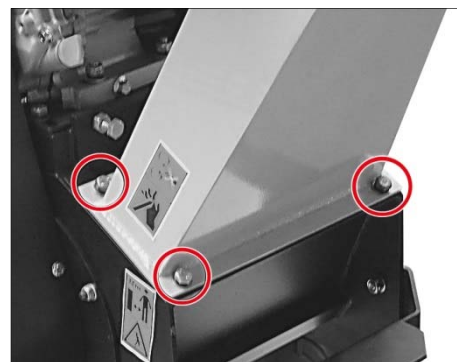

Mounting the ejection chute

ATTENTION! Check all screw connections again and retighten if necessary!



IMPORTANT NOTICE!

Check all fluids before commissioning and refill as described if necessary to avoid damage to the machine.

13. Drive type

13.1 Gasoline engine

The machine is powered by a gasoline engine. For instructions on starting and stopping the gasoline engine, please refer to the engine user manual or the next pages of this manual. [See also... COMMISSIONING / start process \(14.2\) and switching off the engine \(14.3\)](#)



IMPORTANT NOTICE!

When delivered, the engine of the machine does not contain engine oil and fuel. Fill the drive motor as described under "REFUELLING".

13.2. Refuelling



WARNING!

You may only carry out the work described in this chapter after you have read and understood the safety instructions. It concerns your personal safety.

13.2.1 Filling up engine oil



IMPORTANT NOTICE!

Engine oil must be filled up before the first commissioning! Incorrect oil filling can cause irreparable damage to the engine. In this case, the seller as well as the manufacturer distance themselves from any warranty claims.

- Set up the machine level and stable so that the engine is horizontal.
- Use commercially available engine oil with the **specification SAE 10W-30 or 10W-40**.
- Correct oil level is between upper and lower level.

Check engine oil level

Switch off the engine and let it cool down.

1. Unscrew the oil dipstick (13).
2. Wipe the oil dipstick with a clean rag and reinsert, do not screw in.
3. Pull out the oil dipstick again and read off the oil level, if necessary fill engine oil up to the lower edge of the oil filler opening. *Use chute!*
4. Tighten the oil dipstick.
5. Wipe away oil residues / contamination.

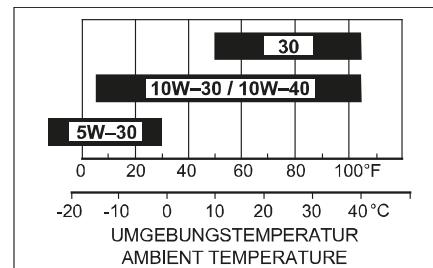

Engine oil viscosity

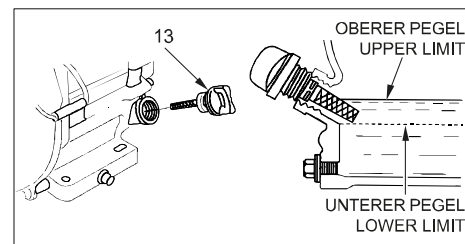

Filling up engine oil

Filling quantity: approx. 1.1 litres
Do not overfill!

ATTENTION!

When the engine is running, the oil filler bolt must always be firmly seated in the filler neck!



IMPORTANT NOTICE!

Using SAE 30 oil below 10°C will result in harder starting and possible damage to the engine bore due to insufficient lubrication.

13.2.2 Fuelling



DANGER!

Health and explosion hazard due to combustion engine. Care must be taken when handling fuel!



The exhaust gas from the engine contains toxic carbon monoxide. Being in an environment containing carbon monoxide can cause unconsciousness and death.



Do not run the engine in a closed room.



Read the user manual for the machine and the engine manual before commissioning.



Keep the engine away from heat, sparks as well as flames. Do not smoke near the machine!



Gasoline is extremely flammable and explosive. Before refuelling, switch off the engine and allow it to cool down.

Only unleaded regular gasoline with a research octane number of 95 is required for this engine. Use only fresh, clean fuel. Water or impurities in the gasoline will damage the fuel system.

When refilling fuel, please note the following:

- Switch off the engine and allow it to cool down for at least 10 minutes before removing the fuel tank cap.
- Keep the engine away from heat, sparks as well as flames.
- Fill fuel outdoors or in well-ventilated rooms to dissipate vapours.
- Keep gasoline away from sparks, open flames, permanent flames, heat sources and other ignition sources.
- Do not spill fuel, use suitable filling aids.
- If fuel has been spilled, wait for vapours to dissipate before starting the engine.

Refuelling

1. Set fuel switch (5) to OFF.
2. Clean the area around the fuel tank cap of dirt and foreign bodies.
3. Unscrew the fuel tank cap (10).
4. Fill fuel tank with **gasoline (ROZ95)**. To allow room for the gasoline to expand, do not fill past the bottom edge of the fuel nozzle.
5. Screw the fuel tank cap tightly onto the tank nozzle.
6. Wipe up spilled gasoline immediately.

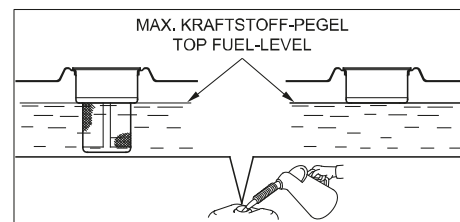

Fuel

Tank volume: approx. 6.5 litres
Do not overfill!

Store fuel

- Fuels can only be stored for a limited time, they age. Overstocked fuels and / or fuel mixtures can lead to starting problems. Only store as much fuel as you use in a month.
- Store fuels only in containers specifically approved for this purpose. Keep fuel tanks dry and safe.
- **Store fuel tank out of reach of children.**

14. Commissioning

The machine must not be set up on sloping ground. Special care must be taken to ensure that the ground does not give way under the heavy load of the machine.

Do not work alone, someone must be nearby (within calling distance) for emergencies.

14.1 Preparation for the site of operation

- Make sure that the machine is completely assembled according to the instructions.
- All safety installations must be fitted to the machine. They must not be removed or rendered unusable.
- Check the machine for external damage before commissioning.
- Use the machine only on horizontal and solid ground. **Attention, danger of tipping over!**
- Only set up the machine outdoors. Keep at least 3 meters away from house walls or other rigid objects.



WARNING!

The presence of persons, children and animals in the danger zone is prohibited.

Stake out an area at least 3 m wide and 12 m long on the side of the ejector. Check the close range before starting. Pay particular attention to children, other people and animals.

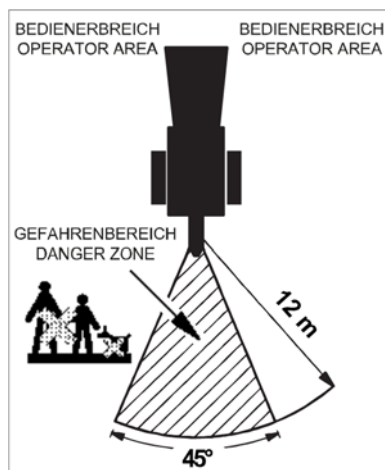

When shredding, shredded material, stones and the like can splash away. No other persons or animals may be present in the ejection area = danger zone.

Also be careful not to damage vehicles, glass windows and other objects.



WARNING!

When shredding, ensure that no one can be injured by ejected shredded material.

- Keep handles dry and clean.
- Before starting work, check the EMERGENCY STOP bar for ease of movement and function.
- Check the blades for perfect condition and proper attachment. Blunted blades can be turned over.
- Regularly check the tyre pressure (approx. 1.7 bar)
- If faults or defects occur, the machine must not be commissioned until these have been rectified.



IMPORTANT NOTICE!

Heavily damaged or bent blades must be replaced with new blades.



WARNING!

Do not operate the machine unless all blades are properly inserted and secured. Furthermore, make sure that all protective devices are in place and in protective position.

- Check oil level and fuel, refill if necessary.
- Check the condition of the air filter, the fuel lines and connections for leaks and mechanical damage, and the fuel tank for cracks and leaks.



DANGER!

Do not start the engine in closed rooms. The exhaust gases contain carbon monoxide, which is very toxic when inhaled!



WARNING!

Warning against hot surfaces!

The engine exhaust and other engine parts become very hot during operation. Never touch the hot engine. Keep a sufficient distance from hot surfaces and keep children away from the running engine.

ATTENTION! Whenever working on the machine, always wear the correct protective equipment and switch off the drive.

14.2 Start process

1. Set fuel switch (5) to ON position.
2. When the engine is cold, move the choke valve (4) to the left to CLOSE (=CHOKE).
When the engine is warm, leave the choke valve (4) on the right in the OPEN position (=RUN), no choke.
3. Push the throttle lever (8) slightly to the left from the idle position LOW (= TURTLE), in the direction of HIGH (= RABBIT).
4. Insert ignition key at E-start (1) and turn to ON position.

→ **Manual start (HAND START)**

5. Slowly pull out the starter grip (2) from the recoil starter until resistance is felt, then tighten with a quick but smooth movement and slowly return. The engine starts.

ATTENTION!

Do not pull the starting rope all the way out and do not let the starter grip handle hit back on the engine.

→ **Start with electric starter (E-START)**

5. Insert ignition key at E-start (1) and turn key to ON position.
Then turn the ignition key further to the START position and hold it in this position for max. 5 seconds.

Release the ignition key as soon as the engine starts. This automatically turns back to the ON position.

ATTENTION!

Do not operate the key switch for more than 5 seconds as the starter motor will overheat and battery power will drop. Repeat this process a maximum of 8 times with a break of 5 seconds each time. Then wait at least 40 minutes to allow the starter motor to cool down. If the engine does not start after the next 8 attempts, consult a specialist garage.

6. If the choke valve (4) was set to CLOSE (=CHOKE) to start the engine, now gradually return it to OPEN (=RUN) while the engine is warming up.

Open the throttle lever (8) fully for operation, slowly move it in the HIGH direction.

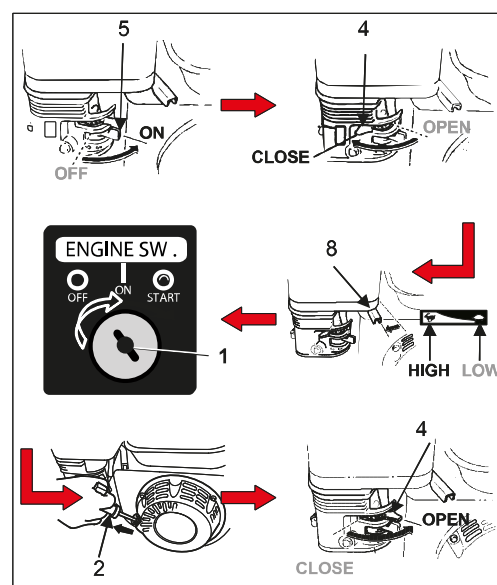

Manual start (HAND START)



IMPORTANT NOTICE!

Suddenly stopping the engine at full throttle can cause engine damage.

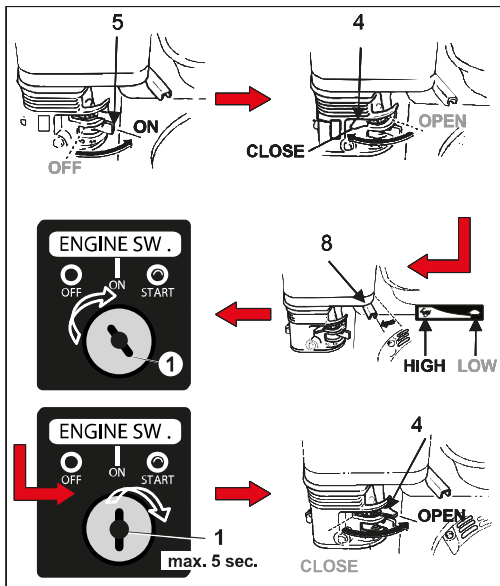

Start with electric starter (E-START)

14.3 Switching off the engine

1. Push the throttle lever (8) to the right to the idle position LOW (=TURTLE).
2. Turn the ignition key on E-start (1) to the OFF position and remove.
3. Then turn the fuel switch (5) to the left to the OFF position to close it.

When leaving the machine, remove the spark plug connector (7) = protection against unauthorised use!

ATTENTION! Never set the choke valve to CLOSE to stop the engine. This can lead to re-ignition or engine damage.

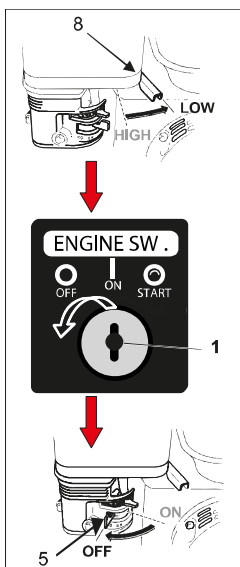

Switch off engine

14.4 Stopping the engine in an emergency

In dangerous situations, machine movements must be stopped as quickly as possible and the energy supply must be switched off.

In case of danger:

1. Press the safety bar (9) on the infeed chute, an EMERGENCY STOP is initiated.
2. Inform the responsible person at the site of operation.
3. If necessary, alert doctor and fire department.
4. Rescue injured persons, initiate first aid measures.
5. Switch off the engine switch (1) and secure it against being switched on again.
6. Keep access routes clear for emergency vehicles.

To restart, push the engine switch to the ON position, then start the engine as described in COMMISSIONING / Start process (14.2).

14.5 Idle speed

When not shredding, move the throttle lever (8) to the LOW position to reduce the load on the engine.

Reducing engine speed at idle extends the lifespan of the engine, saves fuel and reduces noise levels.

15. Shredding operation

Check the machine before each use for:

- loose screws and nuts
- damaged rubber flap in the infeed chute, replace if necessary
- function of the safety circuit
- properly fitted protective devices and their protective position
- engine oil level
- cracks in the cladding sheets and / or loose weld seams
- rotor damage or breakage



Wear tight-fitting clothing and personal protective equipment (PPE)

- Always work on a stable, level ground. Secure the machine against unintentional rolling away (wheel chocks). Do not operate the machine when it is on a slope.
- Do not use the machines without the two wheels and the support foot being mounted.
- The working position is located to the side of the infeed chute of the machine. Never stand in the area of the ejection chute.
- Never use a step ladder or other elevations to feed cuttings into the chute.
- Never reach into infeed or ejection openings.
- Keep face and body away from the infeed opening. Keep a sufficient distance!
- Do not place hands, other body parts, or clothing in the infeed chute or ejection chute or near other moving parts.
- Attention! Keep a safe distance when shredding, do not lean too far forward. Longer shredded material protruding from the chute can bounce back when being pulled in by the blades.
- Before each engine start, check that there are no shredding residues in the chute.
- Shredding may only be carried out after the maximum engine speed has been reached.
- Never tilt the machine while the engine is running.
- When charging, make sure that no foreign objects such as nails, wires, stones and the like get into the infeed chute.

In the case of blockages:



Switch off the engine and remove the spark plug connector for safety reasons!

- Only remove shredded material lying crosswise in the chute when the engine is switched off and the blade drum is at a standstill. Only use another twig or piece of wood to remove it.
- In the event of blockages in the infeed and ejector of the machine, unusual noises or vibrations, switch off the engine immediately. Disconnect the spark plug connector and wait for the tools to stop. Faults must be rectified immediately.
- Never leave the machine unattended while the engine is running.
- When replacing the blades and the counter blade, stop the engine and disconnect the spark plug connector. After one hour of use, check that all screws and nuts are tight.
- Repairs may only be carried out by an approved service centre or our service team.

15.1 What may be shredded?

YES

Organic waste from the garden, such as hedge and tree cuttings, bushes, shrubs and branches up to max. Ø 120 mm.

NO

Stones, roots with soil, glass, fabric scraps, plastic and metal parts, food waste.

15.2 Shredding

Make sure that the shredded material is as DRY as possible! Excessively wet shredded material inevitably leads to blockages and costly cleaning or maintenance work.

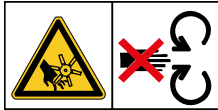

Always keep hands away from infeed and ejection openings!

Branches up to \varnothing 120 mm, twigs, bushes or green waste can be shredded.



WARNING!

Once the motor is running, the blades move and anything fed into the chute will inevitably be shredded.

Put shredded material (branches, twigs, etc.) into the infeed chute. When the machine grabs the branches, let go of the shredded material immediately. The branches are fed in by themselves (automatic infeed). Insert thick branches in a careful manner! Ensure that the engine speed is maintained.

First cut off side branches of more than 3 cm and insert them separately.

Shredded material protruding from the machine can knock around when being fed into the machine. Therefore, keep a sufficient safety distance from the machine.



IMPORTANT NOTICE!

The hardness of the branches to be shredded depends, among other things, on the type of wood, the time between cutting and shredding as well as the dryness of the branches. Optimal results are achieved when the branches are shredded shortly after cutting.

- Thin and long bushes and / or branches are pulled in very quickly. For this reason, let go of this shredded material quite quickly.
- Process highly water-containing shredded material alternately with woody material to avoid blockage in the machine.
- **The cutting unit draws in the shredded material largely independently.**
- Observe the maximum branch diameter to be processed. [See also... TECHNICAL DATA \(9.\)](#)
- Depending on the type and freshness, the maximum branch diameter may be reduced.

- If the cutting unit is blocked, switch off the engine immediately to avoid overloading the engine. Remove spark plug connector and eliminate fault!

In case of unexpected circumstances, never hesitate to operate the safety bar (EMERGENCY STOP) (9) on the infeed chute.

The safety bar (EMERGENCY STOP) (9) may only be operated in an emergency. To shut down the machine normally, first allow the engine to continue idling and then switch it off and secure it against restarting. To do this, set the motor switch (1) to OFF. [See also... COMMISSIONING / Switching off the engine \(14.3\)](#)

When you stop shredding, give the machine enough time to “spin clean”. This prevents starting problems during the next shredding.

16. Maintenance and repair work



Before all maintenance and repair work on the machine:

- Shut down the drive and secure it against restarting and unauthorised commissioning.
- For gasoline engines, disconnect the spark plug connector.
- Clean the machine of branches, twigs, green waste and other contamination.

Never leave the machine running unattended.

Never work without protective devices. After maintenance and repair work, refit all protective devices.

Wear personal protective equipment:

- Protective clothing
- Solid protective gloves when working on components, chemical-resistant protective gloves when handling hazardous materials
- Non-slip safety shoes
- Safety goggles with side protection when working on pressurised components or in the vicinity of pressurised systems

Use only original LUMAG spare parts. Other parts may cause unpredictable damage and injury.

Work on the electrical equipment may only be carried out by qualified electricians.

Before starting work, the operator must ensure that the machine is in safe operating condition.

16.1 Maintenance work

To maintain the value and a long service life, you should observe the following points:

- Ventilation slots should be kept clear and clean.
- Check the machine, especially the fuel system and fuel tank cap for leaks.
- The machine is exposed to vibrations during operation. Check the fixing screws and retighten them if necessary.

- Infeed chute and blades must be carefully maintained to avoid damage and injury.
- After the shredding process, the inside and outside of the machine should be cleaned. Please use only a warm damp cloth and a soft brush. Do not use cleaning agents or solvents, as these can cause irreparable damage to the machine.
- Please do not clean the machine with running water or even a high-pressure cleaner.
- Please treat bare metal parts after each use with an environmentally friendly, biodegradable spray oil to protect against corrosion.

16.2 Maintenance plan

The following sections describe the maintenance work which is required for optimum and trouble-free operation.

Maintenance work	Before each use	After each use	After 1 OH*	After the first 5 OH*	Every 25 OH*	Every 30-50 OH*	Every 100 OH*	As needed	Every season
Check machine	■								
Check safety circuit (EMERGENCY STOP)	■								
Check protective devices and rubber protection flap	■								
Check fastening screws, retighten if necessary			■						
Refuel and check oil level	■								
Change engine oil				■		■			
Change gasoline									■
Clean air filter	■				■				
Replace air filter								■	
Check spark plug and spark plug connector							■		
Replace spark plug									■
Clean machine		■							
Check V-belt	■								
Check blades	■								
Change blades						■ ¹			
Lubrication blade drum	■			■					
<p>*OH = Operating hours ¹ under normal operating conditions</p>									

General maintenance plan

16.3 Lubricants



IMPORTANT NOTICE!

Fuels and lubricants used must comply with the operating material regulations of the operator and the stated specification. Consult the supplier if necessary.

Fuel	Assembly	Specification	Filling quantity
Fuel	Engine	Gasoline ROZ95 or higher	6.5 litres
Engine oil	Engine	10W-30 or 10-W-40	1.1 litres
Grease	Lubrication	Multi-purpose grease with EP properties KP2K-20	1-2 stroke (grease gun)

Operating material specification

16.3.1 Greasing the blade chassis

Lubricate the bearings of the blade drum on both sides at the two grease nipples (1+2) with a grease gun **before each use and / or after 5-10 operating hours and after each cleaning.**

The 2nd grease nipple is located behind the V-belt protection.

1. Loosen the 4 fastening screws on the belt cladding and remove the cover.
2. Clean the grease nipples with a rag.
3. Apply the grease gun to all nipples one after the other and pump in grease.
4. Wipe away any excess grease.



WARNING!

After lubrication, the V-belt protection must be properly refitted.

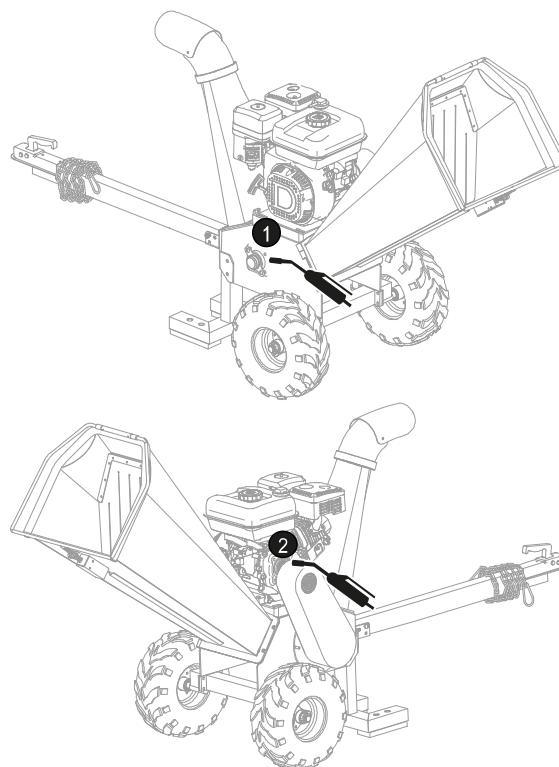

Lubrication points blade chassis

16.3.2 Changing the engine oil



IMPORTANT NOTICE!

The engine oil must be changed after the first 5 hours of operation.

Change the engine oil when the engine is warm (oil then drains quickly and completely). Disposal according to environmental regulations.

Assembly	Number	Interval (OH*)	Quantity
Engine oil change - initial commissioning	1	5	1.1 litres
Engine oil change operation *or 1 x per season	1	50*	1.1 litres

* Operating hours

To change the oil:

1. Unscrew the oil drain bolt (13)
2. Hold a suitable container (at least 2.5 litres) under the oil drain bolt
3. Tilt the machine with a 2nd person so that the oil drains off

4. Thoroughly clean the area around the oil outlet port
5. Screw in the oil drain bolt again
6. Slowly fill 1.1 litres of engine oil into the oil filler bolt
7. Tighten the oil filler bolt
8. Remove oil residues and / or contamination
9. Engine oil must be disposed of in an environmentally friendly manner in accordance with local regulations

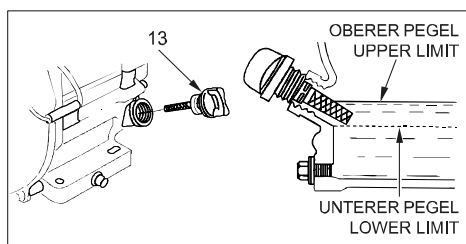

Oil change, upper and lower level

ATTENTION!

Observe oil level. Do not operate the engine with too much or too little engine oil. See also... Fig. Oil change, upper and lower level.

16.4 Blades

Blades are blunt when

- the shredding noise sounds ponderous.
- the shredding speed has decreased considerably.
- the drive belts slip despite tension.

After approx. 30-50 hours of operation, the cutting edges of the blades are blunted under normal operating conditions.

The two drum blades have two cutting edges and can therefore be turned once.

The fixed counter blade can be turned once.

Adjust the counter knife to a cutting gap of 0.5 mm using a thickness gauge. Then tighten the fixing screws with 60 Nm and medium thread locking adhesive.

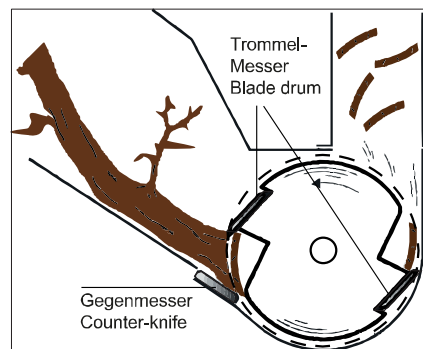
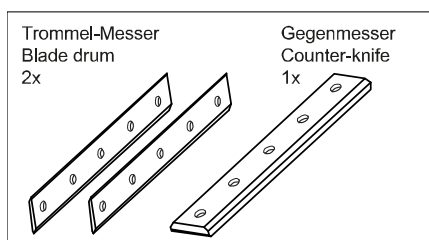

Blade chassis

Blunted blades can be turned over. Damaged blades (cracked, chipped, severely bent or otherwise damaged) must be replaced immediately.



DANGER!

The machine must not be put into operation if the blades are not fully inserted!

The original designs of the manufacturer must be used for all spare parts.

16.5 Drive belt



IMPORTANT NOTICE!

Check the condition of both drive belts before each commissioning. Drive belts must be pre-tensioned in such a way that they can be pushed through approx. 8-10 mm in the middle using thumb pressure.

When changing the belt, both drive belts must always be changed.

Installed drive belts: 2 pieces

16.5.1 Check drive belt for wear and tension

To check the drive belts:

1. Remove belt cover
2. If the drive belts show wear, both must be replaced

See also... Replacing / tightening the drive belt (16.5.2)

ATTENTION!

Place the belt loosely on the drive pulley to prevent damage (drive belt tear).

16.5.2 Changing the drive belt

To change / tension the drive belts:

1. Remove belt cover
2. Loosen four screws on the motor plate
3. Loosen the lock nut on the clamp screws
4. Move the motor plate until the old drive belts can be removed
5. Put on new drive belts
6. Tension belts, tighten motor plate with clamp screws until drive belts are tight (movement towards each other 8-10 mm)
7. Drive and engine belt pulley must be aligned
8. Tighten four screws on the motor plate and lock nut
9. Replace belt cover

Interval: in case of wear



IMPORTANT NOTICE!

Always replace excessively long, damaged and / or worn drive belts with new original drive belts.

16.6 Changing / cleaning the air filter



DANGER!

Fire and explosion hazard when handling flammable liquids!

Fuels can burn explosively and cause poisoning or skin irritation.

– Do not clean the air filter element with flammable liquids

To clean and / or change the air filter and / or insert:

1. Loosen and remove the air filter cover
2. Wipe off dirt from the inside of the filter housing with a clean, damp cloth
3. Carefully remove the foam filter insert from the paper filter insert. Check both parts for damage, replace damaged inserts if necessary

4. Clean foam filter element in warm water and mild soap solution. Rinse thoroughly with clean water and allow to dry thoroughly.
5. Tap out dirt from the paper filter insert on a hard surface, do not brush it off as this will push it into the fibres.
6. Place the foam insert on the paper filter insert
7. Install filter element
8. Put on the air filter cover and screw it tight

Interval: in case of defect or wear



IMPORTANT NOTICE!

Do not run engine without or with damaged air filter insert. Dirt thus gets into the engine (engine damage is the consequence = loss of warranty).

16.7 Checking / replacing / cleaning the spark plug



DANGER!

Risk of burns!

Engine and parts (e.g. muffler or the cooling fans) heat up strongly during operation.

Observe cooling times.

– wear heat-resistant protective work gloves.

For checking, cleaning and / or changing the spark plug:

1. Remove the spark plug connector from the spark plug and remove any dirt in the spark plug area
2. Unscrew spark plug with spark plug wrench and check for condition. In case of damage such as insulator cracks or splinters, replace spark plug
3. Clean spark plug electrodes with a wire brush
4. Check electrode gap (0.7-0.8 mm) and adjust if necessary
5. Screw in spark plug manually and tighten with spark plug wrench
6. Put the spark plug connector on the spark plug

Interval: in case of defect or wear



IMPORTANT NOTICE!

A loose spark plug can overheat and damage the engine. Overtightening the spark plug can damage the thread in the cylinder head.

Guideline:

→ Used spark plug: 1/8 - 1/4 turn

→ New spark plug: 1/2 turn

16.8 Safety installations

Check safety installations (EMERGENCY STOP) for function and perfect technical condition, replace damaged components if necessary.

Interval: weekly

16.9 Checking wheels and tyre pressure

Wheels (tread and tyre condition) and tyre pressure:

- Check the screw connection on the wheel axles for correct seating
- Look out for cuts and foreign bodies in the tread of the tyres.
- Check tyre pressure, max. 2.5 bar.

Interval: weekly

16.10 Rubber protection flap

If the rubber protection flap (8) shows wear, it must be replaced.

Interval: with wear

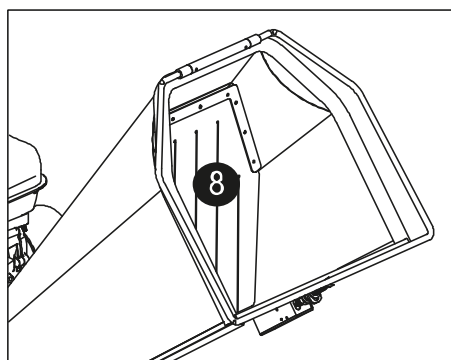

Rubber protection flap

16.11 Cleaning the machine

Check the machine for contamination after use. Dirt accumulation (twigs, wood debris, dust, adhering leaf green, etc.) inside the machine must be removed.

Interval: after use

In the event of contamination:

1. Switch off the machine and secure it against being switched on again (disconnect the ignition plug).
2. Remove contamination properly. Keep in mind:
 - do not use a high-pressure cleaner
 - do not use aggressive cleaning agents
 - take up oil separations with binding agent
 - dispose of cleaning cloths and processing residues in an environmentally friendly manner in compliance with applicable local regulations
 - use a soft brush or a vacuum cleaner for interior cleaning

After the cleaning work, check that all previously opened covers and safety devices have been properly closed again and are functional

ATTENTION!

After cleaning and when the machine is not in use for a longer period of time, all moving parts must be greased or oiled.



IMPORTANT NOTICE!

Do not allow water to get on the bearings or on the motor during cleaning. It can get into tight slots and damage spindles, pulleys, bearings and the engine. After cleaning, grease or oil all lubrication points and run the machine briefly to force out any water that has entered.

16.12 Checking, retightening the fastening elements

Switch off the machine and secure it against being switched on again.

1. Check all screw connections for tight fit, retighten loose screw connections if necessary.

If necessary, replace screw connection elements that cannot be tightened with new bolts and nuts.

2. Check the technical condition of the blades by visual and tactile inspection, if necessary replace the blades immediately if defects are detected.
3. If cracks or other damages are evident, determine the cause, repair welded joint and reinforce the joints.
4. Check other fastenings such as glued joints, pin connections, etc. for technical condition by visual and tactile inspection; if necessary, repair loosened connections properly.

Interval: weekly

16.13 Checking, repairing the construction

1. Check the entire steel construction for proper technical condition by visual inspection.
2. Have detected defects such as hairline cracks, gaps, deformations or loose parts repaired by the manufacturer or an authorised specialist company.
3. Treating paint damage: Clean damaged areas, apply corrosion protection agent, apply new paint after drying.
4. Check all screw connections and fasteners for secure fit, retighten screw connections or replace fasteners if necessary.
5. Check all anchor points for damage and tight fit, if necessary have loosened or damaged components replaced by the manufacturer or an authorised specialist company.

Interval: monthly

17. Transport



DANGER!

Danger of burns due to hot surfaces on the engine!

Contact with hot components can cause burns.

- Wear protective clothing and protective gloves when working near hot components.
- Before carrying out any work, allow the hot components to cool down to below +50°C.

Before transporting and / or relocating or storing indoors:

1. Switch off the engine of the machine and allow it to cool down to avoid burns and exclude fire hazard.
2. Remove spark plug connector.
3. Close fuel switch.
4. Empty fuel tank to prevent fuel overflow.



IMPORTANT NOTICE!

Machines with gasoline engines may be tilted for transport, but must not be turned over any further, as engine oil can get into the air filter.

- This can put the engine out of operation!

The machine must not be tilted more than 20°.

Persons must not be endangered by the machine tipping or slipping, or by machine parts swinging up or down.

17.1 Transport by hand

Grip the machine by the drawbar, lift it slightly and move it.

17.2 Transport with chassis

1. Attach the trailer coupling to the towing vehicle.
2. Connect the safety chain to the towing vehicle.
3. Loosen the screws from the foot and remove the foot.
4. Check tyre pressure, max. 2.5 bar.

ATTENTION!

If the machine is unhitched from the towing vehicle, it must be parked on a horizontal, level and firm ground.

**IMPORTANT NOTICE!**

The machine is not approved for public road traffic.

18. Storage

Storage of the machine and temporary shutdown.

Store the machine under the following conditions:

- Do not store outdoors
- Store upright
- Store in a dry and dust-free place
- Do not expose the machine to extreme and sudden temperature changes
- Protect from sunlight
- Avoid mechanical shocks
- Storage temperature: 5 to 45°C
- Relative humidity: max. 60 %.
- If stored for longer than 3 months, regularly check the general condition of all parts and the packaging. If necessary, refresh or renew the preservation.
- Remove soil, dirt and debris from engine and machine. Clean the engine with a cloth
- Treat moving parts with environmentally friendly oil (do not use grease!) and commission the machine briefly (let it run for 1-2 minutes)
- Drain fuel by running the engine until fuel is used up
- Clean air filter, replace if necessary
- Check function of all moving parts, repair or replace if necessary
- Remove spark plug connector.
- Check the screws and the counter and shredding blades mounted on the drum
- Check drive belt tension
- Check wheels and tyre pressure
- Secure the machine against rolling away and unauthorised use (wheel chock)
- Cover the machine and engine to protect them from dust

19. Disposal

If the machine is no longer serviceable and is to be scrapped, it must be deactivated and dismantled, i. e. it must be brought into a condition in which it can no longer be used for the purposes for which it was designed.

Disposal of the machine must be carried out by trained personnel. The machine may only be disposed of in the designated and approved ways.

19.1 Decommissioning

Decommissioned machines must be taken out of service immediately in a professional manner in order to avoid later misuse and danger to persons or the environment.

Drain all environmentally hazardous operating materials from the old device and dispose of in an environmentally friendly manner. Oil residues must never be discharged into soil and waste water.

Block every moving machine part and disassemble the machine into its individual parts. Dispose of machine components at controlled disposal points.

Remove rubber and plastic parts from the machine and take them to a designated collection point

19.2 Disposal of electrical equipment

Electrical components belong to hazardous waste and must be disposed of separately from the machine. In the event of a fire on the electrical system of the device, use extinguishing agents that are approved for this purpose (e. g. powder extinguishers).

19.3 Disposal of lubricants

Disposal instructions are given in the product-specific data sheets. If necessary, consult your lubricant manufacturer.

20. Troubleshooting



WARNING!

Any faults on the machine or engine requiring major intervention must always be repaired by your LUMAG workshop or authorised specialist workshops. The warranty becomes void in the event of improper intervention.



Before any troubleshooting

- Switch off machine
- Wait for the shredding blades to come to a standstill
- Remove spark plug connector.

PROBLEM	POSSIBLE CAUSE	PROPOSED REMEDY
Engine will not start	No fuel	Fill fuel tank
	Recoil starter defective	Repair or replace recoil starter
	No engine oil	refill engine oil
	Engine is still in the cooling phase	Let engine cool down
	No spark	Clean or replace spark plug
	Engine in cold condition and choke set to OPEN (right)	Set choke to CLOSE position (left)
	Fuel switch set to OFF	Set fuel switch to ON
Engine is difficult to start or runs poorly	Fuel mixture too greasy	Set choke to OPEN (right) position
	Carburettor incorrectly adjusted	Have adjustment carried out by specialist dealer
	Faulty spark plug, dirty or incorrectly adjusted	Clean, readjust or replace spark plug
Engine gets too hot	Too little engine oil	Refill engine oil
	Cooling air system restricted	Clean ventilation grille, clean internal cooling fans
	Air filter dirty	Clean filter element, replace if necessary
	Carburettor not adjusted correctly	Have carburettor adjusted by specialist dealer
Engine brings too little power	Air filter dirty	Clean filter element, replace if necessary
	Machine is overloaded	Reduce material supply, observe max. Ø of branches!
	Machine is blocked	Clean the machine thoroughly from the inside
Reduced cutting performance and / or decreases	Blades are dull	Turn or replace the blade
	Counter blade is worn	Turn or replace counter blade
	V-belt slips	Tension the V-belt
Shredded material is not automatically drawn in	Blades are dull	Turn or replace the blade
Excessive vibration	Blades, screws, nuts or other parts loose	Switch off engine immediately. Check all nuts and screws for tight fit, replace damaged parts, adjust V-belt tension.

If these measures do not eliminate the fault or if faults occur which are not listed here, then have your machine checked by a specialist.

21. Warranty / Guarantee / Customer Service

WARRANTY

The statutory warranty period is given on the device. The seller must be notified immediately of any defects that can be proven to be due to material or assembly faults. Proof of purchase of the device must be provided by presenting the invoice and receipt when making a claim under the warranty.

The warranty is excluded with regard to parts if defects are caused by natural wear and tear, temperature, weather conditions, as well as defects resulting from negligent assembly, faulty connection, wrong fuel / fuel mixture, installation, operation, maintenance, lubrication or force.

Furthermore, no warranty is given for damage caused by unsuitable, abusive use of the machine, such as improper modifications or repair work carried out by the owner or third parties on his own responsibility, but also in the case of deliberate overloading of the machine.

Parts subject to wear and tear with a limited service life (e. g. V-belt, clutch, throttle cable, spark plug, air filter, battery, blades, hoses, wheels, tools and other aids), as well as all setting and adjustment work are excluded from the warranty.

GUARANTEE

LUMAG guarantees perfect quality and, without prejudice to the statutory warranty, provides a warranty in the event of material or manufacturing defects. The guarantee for LUMAG products is 24 months in the case of exclusively private use, and 12 months from the date of delivery in the case of commercial and / or professional use and / or leasing.

Guarantee claims must always be proven by the purchaser by means of the original purchase receipt. A copy of this must be enclosed with the guarantee application. Buyer's address and machine type must be clearly identifiable in the case of professional and / or commercial use. Without the original purchase receipt, we can only carry out the repair against payment.

Please do not return any equipment to us without a SERVICE NUMBER that you have received from our service department. If we receive devices

unsolicitedly, we cannot accept and process them. To request a SERVICE NUMBER, please contact our service team at:

info@lumag-maschinen.de

Please label the shipping carton clearly with the SERVICE NUMBER to ensure quick allocation.

Guarantee work is carried out exclusively by our LUMAG service workshop. Defects occurring within the guarantee period due to material or manufacturing defects shall be rectified by means of a repair, provided that they occurred despite proper operation and care of the device. In this case, we reserve the right to rectify the defect twice in the case of the same defect. If rectification fails or is impossible, the device can be exchanged for an equivalent device. If the exchange is also unsuccessful or impossible, there is the possibility of conversion.

Normal wear and tear, natural aging, improper use, as well as cleaning, maintenance and adjustment work are generally not covered by the guarantee (e. g. cutting device, air and fuel filter, spark plug and recoil starter, drive belt and the like). Due to operation and use, some components are subject to normal wear and tear, even when used as intended, and may need to be replaced in good time.

CUSTOMER SERVICE

For technical questions, information about our products and for spare parts orders, our service team is at your disposal as follows:

Service time:

Monday till Thursday from

7.30 a.m. - 12.00 p.m. and 1.00 p.m. - 5.00 p.m.

Friday from 7.30 a.m. - 12.30 p.m.

Phone: +49 / 8571/92 556-0

Fax: +49 / 8571/92 556-19

Email: info@lumag-maschinen.de

22. CE Declaration of conformity

In accordance with the provisions of the EC Directives

Machinery Directive 2006/42/EC
EMC Directive 2014/30/EU
Outdoor Directive 2000/14/EC

the company

LUMAG GmbH
Rudolf-Diesel-Straße 1a
D-84375 Kirchdorf a.Inn
Phone: +49 8571 / 92 556-0
Fax: +49 8571 / 92 556-19

explains that the product

Designation: Shredder
Type designation: RAMBO-HC15

complies with the essential protection requirements of the above-mentioned EC directives. Conformity is based on the following standards:

EN ISO 12100:2010
Safety of machinery - General principles for design - Risk assessment and risk reduction

EN ISO 14982:2009
Agricultural and forestry machinery - Electromagnetic compatibility - Test methods and acceptance criteria

EN ISO 3744:1995
Acoustics - Determination of sound power levels of noise sources using sound pressure - Engineering method in an essential free field over a reflecting plane

EN ISO 11094:1991
Acoustics; test code for the measurement of airborne noise emitted by power lawn mowers, lawn tractors, lawn and garden tractors, professional mowers, and lawn and garden tractors with mowing attachments

Authorised representative for the compilation of technical documentation: Christopher Weißenhorner

The declaration of conformity relates only to the machinery in the state in which it was placed on the market and does not take account of parts and / or operations carried out subsequently by the end user.

Kirchdorf, 11/07/2017 Christopher Weißenhorner, Managing Director

Place / date

Distributor, authorised representative

Signature



23. Components RAMBO-HC15

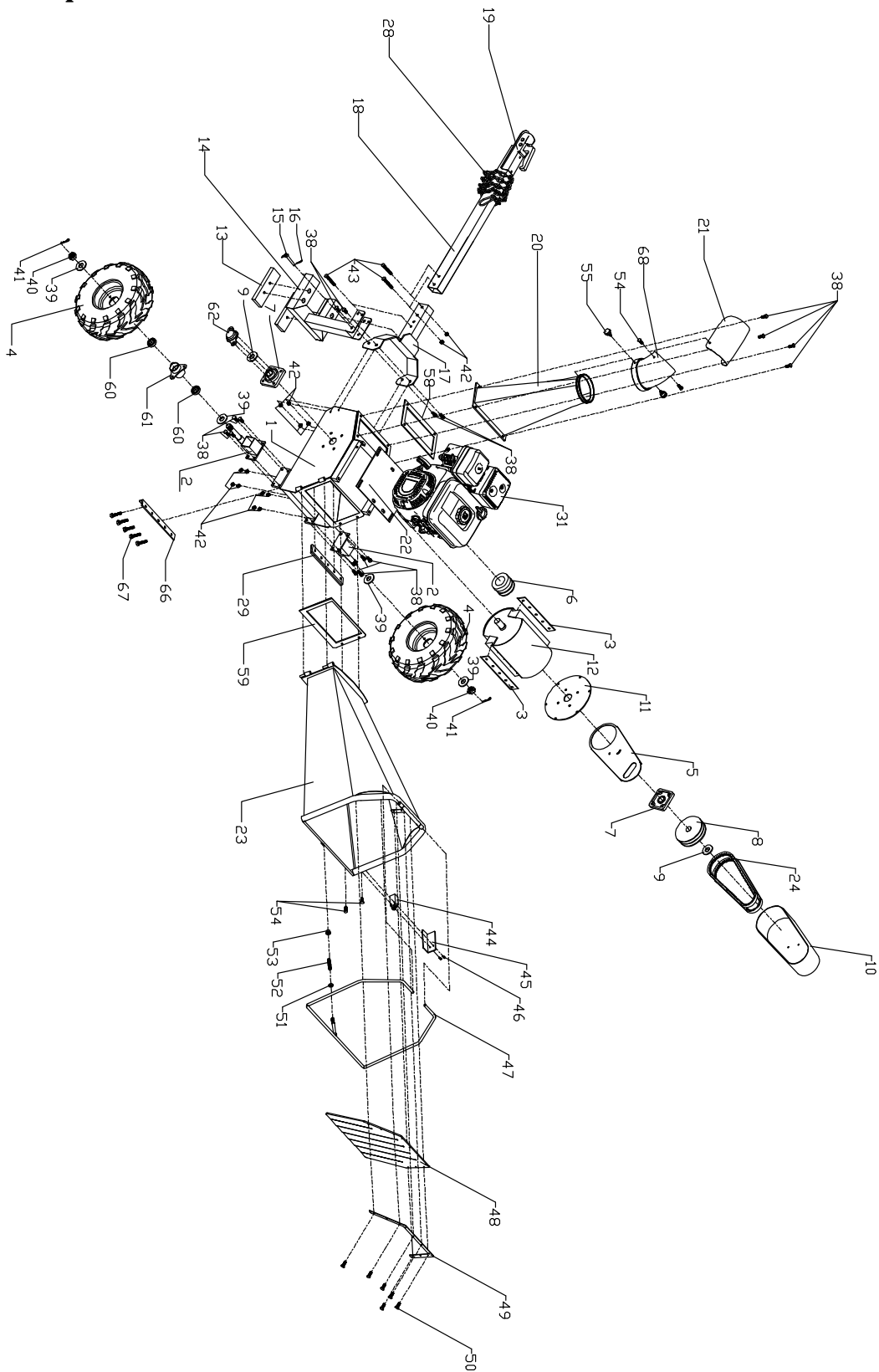

WARNING!

All repairs to the machine must be carried out by authorised qualified personnel. Have any necessary electrical work carried out only by an approved specialist.

Subject to change without notice!

Version RAMBOHC15 (11.2017 en)

LUMAG dealer
can be found at www.lumag-maschinen.de

LUMAG GmbH
Rudolf-Diesel-Str. 1a
D-84375 Kirchdorf a.Inn
Germany
Internet: www.lumag-maschinen.de

