



HOS-5N

Hydraulic Log Splitter

PRODUCT-INFORMATION

Technical Data

HOS-5N

Operating Voltage	230 V / 50 Hz
Motor Power P1/P2	1,5 kW / 0,989 kW
Operating Mode	S3 80%
Motor Speed	2885 rpm
Protection Class	IP54
Splitting Force	5 t
Splitting Length	150 – 520 mm
Splitting Diameter	50 – 250 mm
Hydraulic Oil Tank	max. 3,2 Liter (HLP46)
Hydraulic Pressure	18 MPa
Forward Speed	ca. 3,2 cm/s
Reverse Speed	ca. 6,5 cm/s
Dimensions without Stand	1380 x 465 x 650 mm
Weight (net / gross)	59 / 63 kg
Packaging Dimensions (LxWxH)	960 x 380 x 510 mm

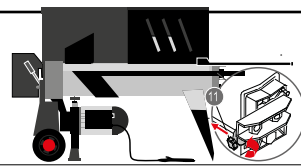

With Stroke Limiter



Art. No.: HOS5N

EAN: 40 47424 00709 9

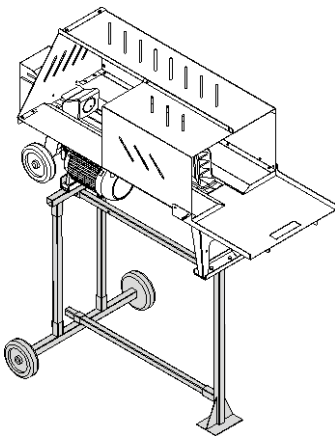

Stand, Art. 5UGHOS5N optional

Equipment Features:

- Anti-splitting device for more safety (according to 2017 standard)
- Horizontal design
- Compact and powerful, ideal for splitting firewood
- Sturdy, torsion-resistant steel construction
- Two-hand safety operation
- 2 wheels and a handle for easy transport
- With stroke limiter as standard! By adjusting the stop, an adjustment to any log length between
- 150 - 520 mm can be made.

Accessoire (optional):

Stand with transport wheels, 8 kg / Art.No. 5UGHOS5N
EAN: 40 47424 00710 5