

WS-700T

Log Saw

PRODUCT-INFORMATION

Technical Data

WS-700T

Operating voltage	AC 400V/3P+N+PE/50Hz
Motor power	5,0 kW E-Motor/S2 15min
Motor speed	1400 rpm
Protection class	IP 54
Phase inverter	Yes
Electromagnetic self-service brake	Yes
Carbide saw blade Ø	700 mm
Bore (flange)	30 mm
Number of teeth	64
Cutting capacity-Ø, max.	250 mm
Rocker support	740 mm
Sound power level LWA	115 dB(A) k=4 dB(A)
Dimensions (LxWxH)	1173(1098) x 740 x 1091 mm
Packaging (LxBxH)	1075 x 790 x 1223 mm
Weight (net / gross)	92,5 / 114,5 kg



Art. No.: WS700T

EAN: 40 47424 00717 4

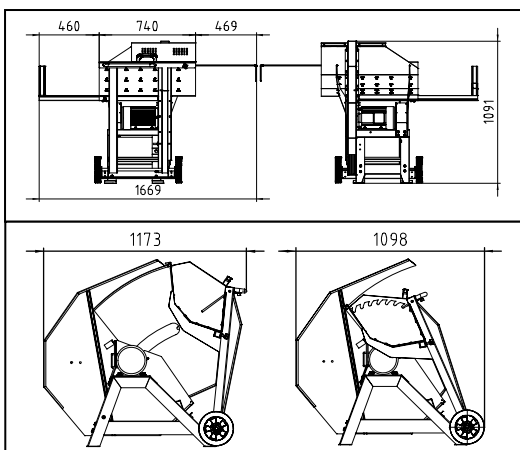

Equipment Features:

- Closed saw guard for more safety (acc. to 2017 standard)
- Sturdy, torsion-resistant all-steel construction
- Robust and powerful circular saw motor
- Stamped barbs in the feed rocker prevent rotation of the wood
- Rocker reset via spring
- Rocker support extension as a standard feature
- Transport lock
- Travelling device for easy transport
- Carbide saw blade Ø 700 mm
- Tool for saw blade change
- Immediately ready for use in a few steps

Optional Accessoire:

Carbide saw blade Ø 700 mm, 64Z (Art. No. 5WS700HM, EAN: 40 47424 00409 8)